

78



**GRAVELLY®**

**READ THIS MANUAL BEFORE ATTEMPTING  
TO OPERATE THE EQUIPMENT.**

**OPERATOR'S  
MANUAL**

**800  
SERIES**

22454 (5/78)  
Printed in U.S.A.



The 800 Series Gravely Lawn and Garden Compact Riding Tractors covered in this manual are:

810 - 10 HP

812 - 12HP

816S - 16HP

816T - 16HP

818T - 18 HP

Power is supplied by an engine transmission combination over the rear wheels for maximum traction and minimum power losses. With the all gear multi-speed transmission and constant speed power take-off. The tractor can handle most grounds maintenance and gardening jobs.

The 800 Series tractors offer year-around, all-season versatility with many different attachments available.

The tractor will give you highly satisfactory service if maintained and operated as outlined in this manual.

All references to Left Hand and Right Hand; front and rear are given from the operator's position.

It is important that you know the Serial Numbers of your tractor for your future reference. Please fill in the numbers as soon as possible.

Tractor Serial Number \_\_\_\_\_

Engine Model Number \_\_\_\_\_

Engine Specification Number \_\_\_\_\_

# KNOW THE GRAVELY

Read this manual carefully and understand how to operate and maintain The Tractor *before* attempting to use it. The Tractor has been designed and built to traditionally high standards for which it is famous. With proper operation and maintenance The Tractor will *perform* for many years to come.

Before actually using The Tractor with an implement (*after reading and understanding this manual*) spend some time with it to get the feel and confidence of what The Tractor can do. Practice starting, turning, backing, changing directions, gear changes, stopping, etc. Knowing how to use The Tractor is the largest part of getting the job done.

It is very important that the SAFETY PRECAUTIONS be read, understood and adhered to. Remember, Safety First!

## ABOUT THE WARRANTY

The Gravelly is designed and built for longevity. To maintain warranty, it is the owners responsibility to have it operated and maintained as outlined in this manual. A failure due to lack of maintenance or improper use is not covered by warranty.

It is the nature of machines to "wear out". A failure due to a defect usually shows up early in the life of a machine. When The Tractor is in the warranty period, the manufacturer or manufacturer's authorized representative will decide whether a part is defective or worn-out.

(The warranty statement appears in the back of this manual)

## CONTENTS

INTRODUCTION .....	2
SAFETY OPERATING PRACTICES .....	3
CONTROLS .....	5
OPERATION .....	8
SERVICE INTERVALS .....	9
MAINTENANCE & ADJUSTMENTS .....	10
STORAGE .....	17
TROUBLE SHOOTING .....	17
SPECIFICATIONS .....	18
EQUIPMENT CHARTS .....	19

# SAFETY OPERATING PRACTICES

Since the tractor is seldom used without powering some type of equipment, these precautions are also directed towards the operation of that equipment.

Improper use of the tractor and its attachments may result in damage to the machinery and/or injury to the operator. Practice these safety precautions and pay attention to the job being done.

## TRAINING

1. Read this manual and the attachment manuals. Be thoroughly familiar with the controls and proper use of the equipment. Know how to stop the unit and disengage the controls quickly.
2. Never allow children to operate the equipment. Never allow adults to operate equipment without proper instructions.
3. Keep area of operation clear of all persons, especially small children and pets. Never direct the attachment discharge toward bystanders or allow anyone in front of the unit.

## PREPARATION

1. Thoroughly inspect the work area where the equipment is to be used and remove all stones, glass, metal, bones, sticks, wires and any other foreign objects. Stay alert for holes and other hidden hazards.
2. Before attempting to start the engine, the PTO must be in the OUT position and the Direction Control lever in Neutral to engage the interlock switches.
3. Do not put hands or feet near or under rotating parts.
4. Never operate the machine without good visibility and light.
5. Do not wear loose fitting clothing or accessories that might get caught in moving parts or on the controls. Keep hands, feet, hair, clothing, etc., away from moving parts. Wear eye protection.
6. Never attempt to make any adjustments while engine is running (except where specifically recommended by the manufacturer).
7. Handle fuel with care, it is highly flammable.
  - (A) Do not smoke while handling fuel.
  - (B) Use approved fuel container.
  - (C) Never add fuel to a running engine or hot engine.

- (D) Fill fuel tank outdoors with extreme care. Never fill fuel tank indoors.
- (E) Replace gasoline cap securely and wipe spilled fuel from equipment.

## OPERATION

1. Operate the tractor only from the operator's position. Keep the feet on the foot rests.
2. Before making any repairs or adjustments, STOP the engine and put the PTO in the OUT position, and set parking brake.
3. When connected power equipment is not in use or is being transported, put the PTO in the OUT position.
4. After striking a foreign object, STOP the engine and put the PTO in the OUT position, and set parking brake, before inspecting for damage. Any damage must be repaired before restarting the equipment.
5. Exercise caution, especially when operating in reverse.
6. Use care when pulling loads or using heavy equipment.
  - (A) Use only the hitch connection points as described in the manual.
  - (B) Limit loads to those that can be safely controlled.
  - (C) Do not make sharp turns especially when backing to avoid jackknifing.
  - (D) Use auxiliary weight when suggested in the attachment manual.
7. Do not operate equipment except from proper operator's position.
8. Keep safety devices and shields in at all times.
9. Do not allow passengers to accompany the operator at any time.
10. Disengage PTO before crossing a gravel drive, walks or roads. Stay alert for hidden hazards or traffic.
11. Use extreme caution when operating on slopes. Reduce speed on all slopes and sharp turns to prevent tipping over or loss of control.
12. Before cleaning, repairing, or inspecting, make certain all moving parts have stopped. Remove the key and disconnect the spark plug wire to prevent accidental starting.

## MAINTENANCE AND STORAGE

13. If the unit should start to vibrate abnormally, stop the engine, disengage the PTO, and check for the cause. Abnormal vibration is generally a warning of trouble. If unable to locate cause, call your service dealer.
  14. Never make an attachment adjustment while engine is running if the operator must dismount to do so.
  15. Take all possible precautions when parking or leaving the equipment unattended: STOP the engine, remove the key, put the direction control in neutral, and lower equipment.
  16. Do not run engine indoors, except when starting engine and for transporting equipment in or out of building. Open outside door as exhaust fumes are dangerous.
  17. Never operate machine at high transport speeds on slippery surfaces.
  18. Disengage the tractor PTO when transporting or not in use.
  19. Do not overload machine capacity by attempting to operate equipment at too fast a rate.
  20. Use only attachments and accessories approved by manufacturer of the equipment. Unapproved attachments can result in damage to the equipment or in personal injury.
  21. Be alert for traffic when near or crossing roadways.
  22. Do not start or stop suddenly when going up or down slopes. When mowing, go up and down the face of slopes, never across. DO NOT mow excessively steep slopes.
  23. When using the tractor with powered equipment, never direct the discharge so as to endanger life or property such as people, pets, structures, cars, etc.
  24. Stay alert for holes in the terrain and other hidden hazards.
  25. Keep the equipment in good operating condition, and keep safety devices in place.
  26. Do not change the engine governor settings or overspeed the engine.
1. Keep all bolts, nuts, screws tight to be sure equipment is in safe working condition.
  2. Never store equipment with gasoline in the tank, inside a building where open flames or sparks are present. Allow the engine to cool before storing in any enclosure.
  3. Keep engine free of grass, leaves, or debris, or excessive grease to prevent overheating and possible fire hazard.
  4. Do not touch the muffler or exhaust pipes until they have had sufficient time to cool.
  5. Do not change the engine governor beyond specified setting. (3600 RPM)
  6. Prevent accidental starting by removing the spark plug wire from the spark plug. Remove the key, and set parking brake when servicing the tractor.

# CONTROLS

## DIRECTION CONTROL LEVER

The Direction Control Lever operates the unique, instant Forward and Reverse clutches that give you instant forward to reverse control of the tractor. DO NOT continuously slip the clutch. MOVE THE CONTROL LEVER TO A FULLY ENGAGED POSITION AS SOON AS POSSIBLE AFTER GETTING UNDERWAY.

The Directional Control lever is located on the right side of the tractor. See fig. 1.

### PROCEDURE

1. Push the lever forward (away from operator) to go forward.
2. Pull the lever back (toward the operator) for reverse.
3. Neutral is a straight up and down (vertical) position.
4. The Direction Control must be in the Neutral position before engine will start due to the ignition interlock switch.
5. The operation of the service brake will return the Control to Neutral. (See Brake) The Control requires routine maintenance lubrication.

## BRAKE-SERVICE AND PARKING

The Brake pedal operates master brake on the transmission. Brake requires adjustment to maintain effective braking. Brake must be adjusted to return Direction Control to Neutral before braking action begins. (See Maintenance)

### SERVICE BRAKE

Pushing on pedal will stop the tractor. Pedal disengages and returns Direction Control to Neutral.

### PARKING BRAKE

Stop-rod: Depress pedal and move stop-rod lever back (toward operator). To release, depress pedal and move stop-rod lever forward. See fig. 1

## GEAR AND RANGE SELECTORS

The controls are used in combination to give you eight ground speeds to select from. Experiment by varying ground speeds to find the optimum speed for the equipment used. CAUTION: DO NOT ATTEMPT TO SHIFT GEARS WHEN MOVING. DAMAGE WILL RESULT. Always come to a complete stop to change range and/or gear. See fig 2.

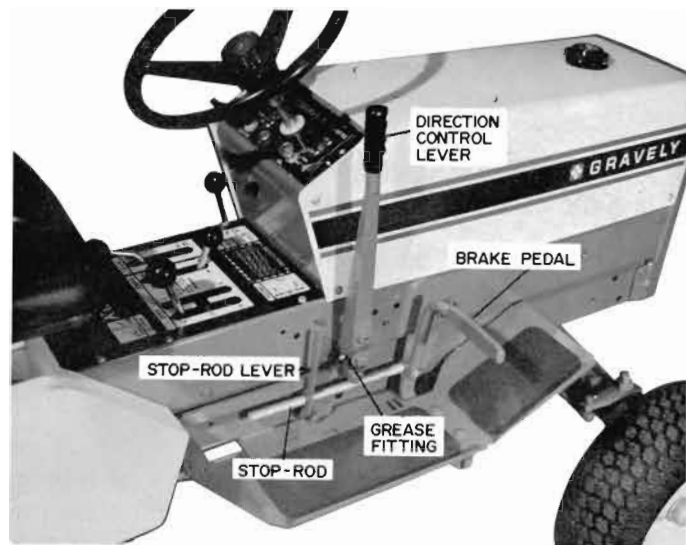

Figure 1

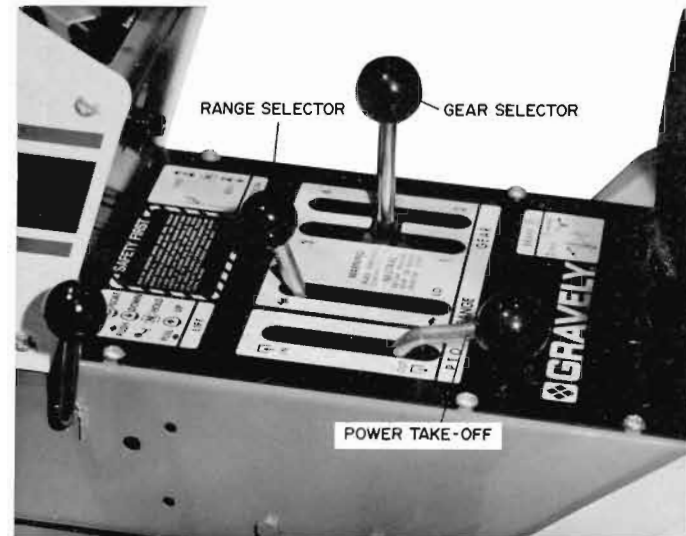

Figure 2

### RANGE SELECTOR

The HI-LO Range has no detented neutral position. The control is either in HI or LO range. The Range Selector significantly affects the ground speed without affecting the PTO speed of the power driven attachment. See ground speed chart on page 18.

### GEAR SELECTOR

The Gear Selector has four gears to choose from. The "NEUTRAL" position is the middle of the "H" pattern.

## PTO CONTROL

The PTO Control (power take-off) engages and disengages the PTO clutch inside the transmission. Follow all SAFETY PRECAUTIONS concerning the PTO. See fig 2.

## PROCEDURE

1. PTO can be engaged at any engine speed.
  - (A) Slowly move control forward to engage. "IN"
  - (B) Do not operate equipment until PTO is fully engaged and engine is at full throttle.
2. Move control back toward operator to disengage PTO.
3. Control must be in OUT position before engine will start due to ignition interlock.
4. Control requires maintenance for free-travel. (See MAINTENANCE)

## EQUIPMENT LIFT

The equipment lift provides a means of raising or lowering front, center or rear mounted equipment. Both HYDRAULIC and MANUAL LIFTS are located on left side of tractor.

### MANUAL LIFT

1. To raise equipment, pull the lever towards operator until it locks. (Will not go back down).
2. To lower equipment, pull back slightly and depress the button on top of lever, and push forward (away from operator). See fig 3.

### MANUAL LIFT POSITION LOCK

The Position Lock limits downward travel of lever and can be adjusted without leaving operator's position. See fig 3.

- (A) To limit downward travel, put the Lift Lever in the raised position. Lift up on the Position Lock and at the same time, pull out towards the operator.

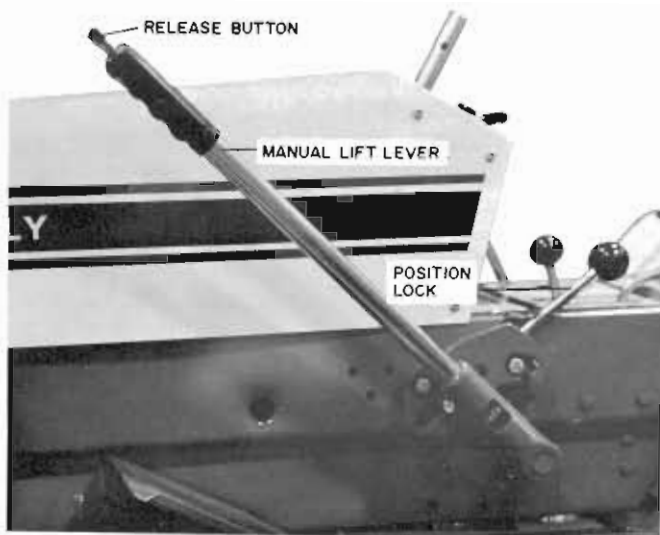

Figure 3

- (B) To put the equipment in the float position, (follow ground contour) put the Lift Lever in the raised position, lift up on the Position Lock and at the same time push in.

### HYDRAULIC LIFT

Basically the system is either on or off. Only use enough pressure on the control to activate the system. Increasing pressure on the control does not increase the speed or power of the system. Laboring on the control will only damage the linkage. Run the engine at full throttle when using the hydraulic lift. Equipment can be lowered without the engine running. See fig 4.

## PROCEDURE

1. To raise, move control back until the equipment is up. Release control to neutral.
2. To lower, move control forward until equipment lowers to the desired position. Release control to neutral.
3. To "Float", push control through the "lower" position down to the "Float position. Control will lock in "Float."



Figure 4

## THROTTLE

Engine speed is controlled by the internal governor at any throttle setting. Engine performance is best at full throttle. DO NOT exceed 3600 RPM.

- A. Full throttle: Push throttle control up and away from operator.
- B. Slow or Stop: Pull throttle control down and toward operator.

The throttle control is located on right side of the Instrument Panel.





Figure 5

## CHOKE

The Choke Control is used to assist in the starting of a "cold" engine. The "ON" position is up and away from operator. "OFF" is down and toward the operator.

The Choke Control is located on the left side of the Instrument Panel.

## IGNITION SWITCH

The Ignition Switch is a three position, key operated switch.

To start the engine, turn key clockwise to "START." As engine starts, release key. Key will return to "RUN" position. "OFF" is counter-clockwise.

If switch fails to activate starter motor, check:

1. Direction Control Lever must be in NEUTRAL to engage ignition interlock switch.
2. PTO must be in OUT position to engage interlock switch.
3. Burned out fuse.

Always remove the key when tractor is left unattended.

## LIGHT SWITCH

The lights are operated by a push-pull switch, located on the Instrument Panel. Pull switch "OUT" to turn lights ON, push "IN" to turn lights OFF. Maintain good electrical connection and replace burned out lamps. NOTE: The 810 model tractor is not equipped with lights.

## FUSE

The fuse holder is located in the lower section of the Instrument Panel. Replace with a 30 amp fuse.

## HOURMETER (Twin Cylinder Only)

The hour meter provides a reliable guide to when maintenance is to be performed.

## FUEL GAUGE

The Fuel Gauge is a float operated mechanism that shows how much fuel is in the tank and is an integral part of the fuel tank cap.

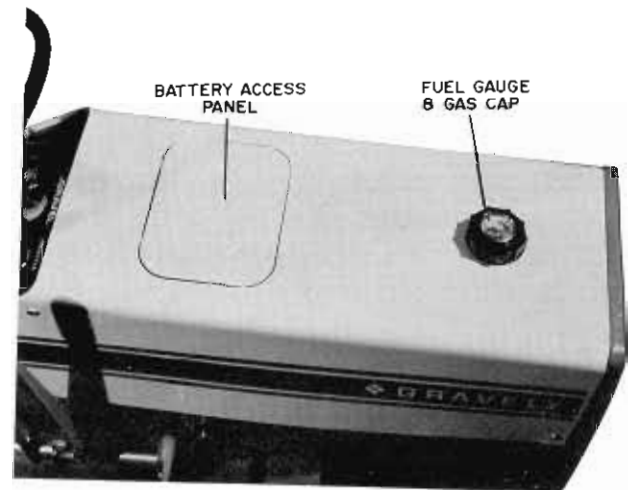

Figure 6



# OPERATION

## INITIAL OPERATION

For the first hour of operation, work under a light to moderate load. (Example: Take a partial swath while mowing.)

## BEFORE STARTING

1. Check oil level in engine.
2. Check fuel level. Use fresh, high quality, regular grade gasoline.
3. Visually check all tires.
4. Check Direction Control and PTO levers. These controls must be in the NEUTRAL or OUT position before the engine will start due to ignition interlock switches.

## STARTING THE ENGINE

1. If the engine is cold, push choke to "ON."
2. Open the throttle about  $\frac{1}{2}$ .
3. Turn ignition key to "START," (clockwise) to engage starter.
4. As engine starts, release, key will return to "RUN."
5. Pull choke to "OFF" and reduce engine speed until operating temperature is reached.

**CAUTION:** DO NOT hold starter engaged over 15 seconds without allowing a one minute cooling period for starter motor.

If engine is warm, leave choke off.

## STOPPING THE ENGINE

1. Close the throttle; all the way down and toward the operator.
2. Allow engine to slow to an idle.
3. Turn key counter-clockwise to "OFF."

## STARTING MOVEMENT

1. Start engine and allow a few moments to warm up.
2. Engage the PTO if power driven attachment is used.
3. Select the desired gear and range.

4. Release parking brake.

5. Advance throttle to fast. (Full throttle)

6. To go forward, push Direction Control Lever forward until it is fully engaged.

7. For reverse, pull Direction Control Lever back until it is fully engaged.

**CAUTION:** DO NOT continuously slip the clutch. Clutch failure will result.

## STOPPING MOVEMENT

1. For sudden and emergency stopping, push on brake pedal. Direction Control will automatically return to Neutral.

**NOTE:** Proper brake adjustment must be maintained.

2. For normal stopping, use the braking action of the Direction Control to engage the forward or reverse clutch.

## PARKING

1. Stop motion.
2. Put controls in neutral.
3. Set parking brake.
4. Lower attachment.
5. Stop engine and remove key.

## PTO

When operating without power driven equipment, keep the PTO control in the OUT position. Always disengage the PTO when transporting power driven equipment.

## EQUIPMENT

Power driven equipment such as mowers, snowblowers, tiller, etc., are designed to operate at full engine throttle. Adjust ground speed gears rather than engine speed to allow equipment to do the job. Always raise equipment and disengage PTO when transporting.

## GEAR CHANGE

Always come to a complete stop before attempting to change gear or range. **SHIFTING ON-THE-GO WILL DAMAGE THE TRANSMISSION.**

## THROTTLE

Run the engine at full throttle when operating under load, especially with power driven equipment. Do not idle the engine for prolonged periods of time, overheating may result causing engine damage. Over all, the engine works best at full throttle. (3600 RPM)

## HEAD LIGHTS

The Ignition Switch must be in the "RUN" position before lights will work on all models. The engine on the 816S also must be running.

## GROUND SPEED

Experiment by varying ground speed to find the optimum speed that the equipment will satisfactorily do the job. The ground speeds suggested below are dependent upon conditions.

1. Ground Engaging Attachments: SLOW ground speed
2. Mowing: MEDIUM ground speed
3. Transporting: HIGH ground speed

This chart is for reference to maintenance scheduling. Some items are scheduled on an operating hours basis while others are performed on an hours/months (which ever occurs first) system. Adjustments are made as they become necessary (due to wear) but should be checked when performing scheduled maintenance.

NOTE: This does not include initial engine oil change to be done after first 5 hours of operation.

every 5 hours & when re-fueling	Check engine oil level
every 8 hrs.	lubricate chasis check battery
every 24 hrs.	clean and inspect air filter
every 24 hrs. or 6 mo.	change engine oil, more often under dusty conditions
every 100 hrs.	816S clean air filter cartridge All models — service spark plug check transmission oil level
every 200 hrs.	check hydraulic fluid level repack front wheel bearings
as necessary	PTO, brake, clutches, cooling systems, electrical connections, fasteners, tires, fuse, lights, steering

# MAINTENANCE & ADJUSTMENTS

## LUBRICATION: ENGINE

### Oil Level:

Maintain at full mark on dipstick. Check before each use and after every 5 hours of operation.

### PROCEDURE

1. Before checking, stop engine, set parking brake, and clean top of fill tube and dipstick to prevent debris from getting into engine.
2. Remove dipstick — wipe clean — put it back in tight — remove and read.
3. Do not operate engine when oil is below add/low mark or above full mark; engine damage may result.
4. Add oil (if necessary) through fill tube until dipstick reads full. DO NOT over fill.
5. Always replace dipstick down tight to prevent air leak and loss of oil.

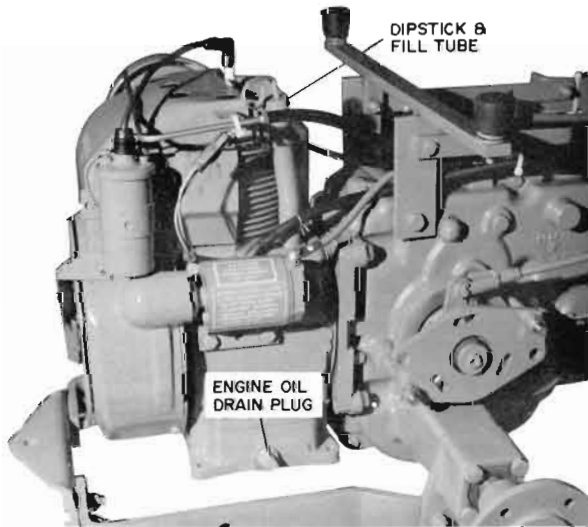

Figure 7



Figure 8

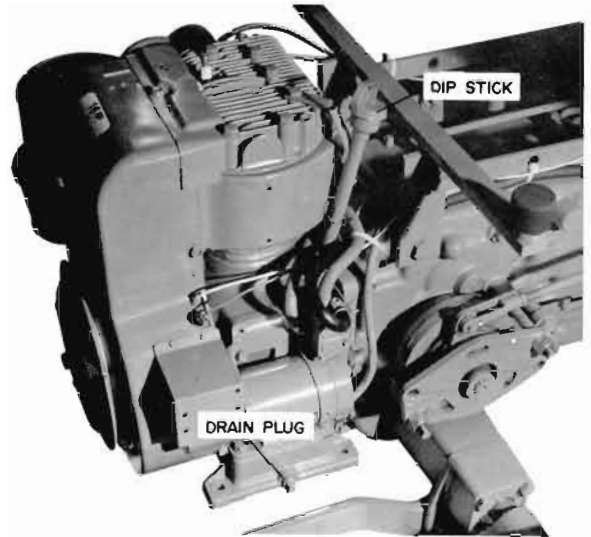

Figure 9

## OIL CHANGE: NEVER USE OIL ADDITIVES

### Capacity

810-812-816S ..... 2 U.S. Quarts  
(1.88 liters)

816T-818T ..... 2¼ U.S. Quarts  
(2.138 liters)

Grade ..... API Service SC

Viscosity ..... Above 0° F SAE 10W-30  
Below 0° F SAE 5W-20  
(-18° C)

## FREQUENCY

Change after initial 5 hours of operation, and then every 24 hours of operation or every 6 months, whichever ever comes first. More often under dusty conditions. The change should be made when the oil is warm and particles are in suspension.

## CHANGE PROCEDURE

1. Run engine until it reaches operating temperature.
2. Stop engine. Clean top of fill tube and dipstick. Remove dipstick.
3. Remove drain plug.
4. Allow engine to drain thoroughly.
5. Replace drain plug.
6. Slowly pour fresh oil into fill tube.
7. Check oil level with dipstick.
8. When changing oil in 816T & 818T without changing filter, add only 1¼ quarts and check level.

Install new filter every other oil change except first 5 hour change. NOTE: Change filter before adding fresh oil. See fig 10.

**PROCEDURE**

1. Remove air seal from filter.
2. Unscrew filter and discard.
3. Put film of fresh oil on new filter gasket.
4. Screw on new filter fingertip tight plus ¼ turn.
5. Replace air seal
6. With new filter; oil level will read high (over full) because oil has not yet been pumped into filter.
7. Run engine and check for oil leak at filter.

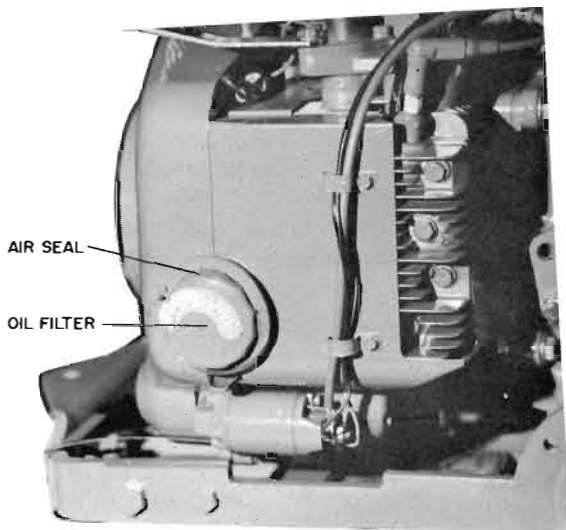

**Figure 10**

**LUBRICATION: TRANSMISSION**

**NEVER USE OIL ADDITIVES**

**CAPACITY: 6 U.S. Quarts (5.7 liters) for all models.**

**VISCOSITY: SAE 10W-30 for all seasons.**

**GRADE: API Classification SE**

**TRANSMISSION SERVICE**

Change transmission oil after first 25 hours of operation. The change should be made when the oil is warm and particles are in suspension. The transmission oil need not be changed after this.

**CHANGE PROCEDURE**

1. Park tractor on level ground, stop engine, set parking brake.
2. Clean all dirt and debris from fill tube cap and check plug.
3. Remove fill cap.
4. Remove drain plug and allow transmission to drain thoroughly. See fig 13.
5. When drained completely, replace drain plug.
6. Remove check plug. See fig 12.
7. Pour fresh oil into transmission fill tube until it shows at the check plug. (The transmission does not have a dipstick.) See fig 11.
8. When oil comes up to the check plug opening, replace plug.
9. Replace fill tube cap. This cap is vented and no other type should be used.

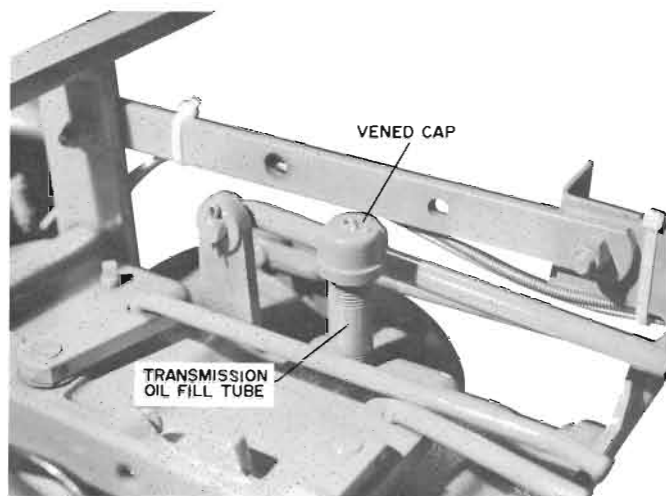

**Figure 11**

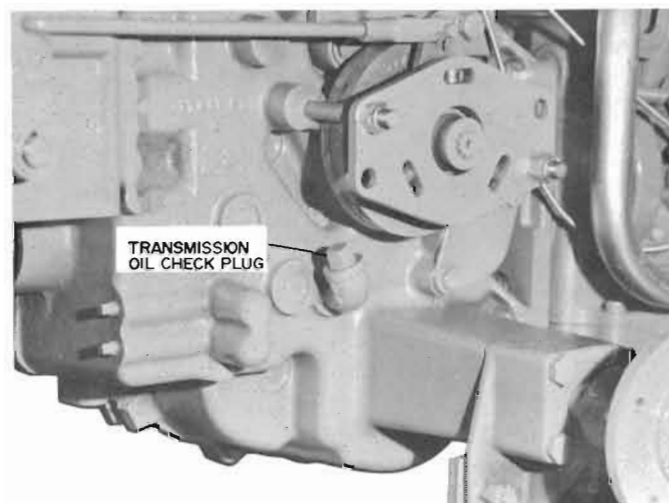

**Figure 12**

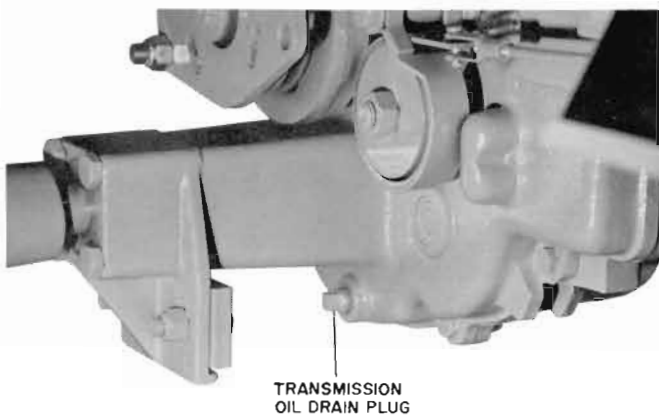

Figure 13

### INSPECTION

Check transmission oil every 100 hours of operation, and while performing routine maintenance.

1. Remove check plug.
2. Maintain oil level up to the check plug hole.
3. Add oil if necessary through the fill tube. (Never over fill.)
4. Replace the check plug.

### HYDRAULIC SYSTEM

NEVER OPERATE ENGINE WITHOUT FLUID IN HYDRAULIC SYSTEM. DAMAGE WILL RESULT.

### FLUID

Automatic Transmission Fluid

TYPE: A Suffix A

Check fluid at regular maintenance intervals. If there is evidence of leakage, have this repaired as soon as possible.

Hydraulic reservoir is located under the tractor hood and between the battery and instrument panel. See fig 14.

### PROCEDURE

1. Run engine until it reaches operating temperature. Fluid must be hot for correct reading.
2. Remove hood and clean top of reservoir to prevent dirt from entering system.
3. Remove plug/dipstick.

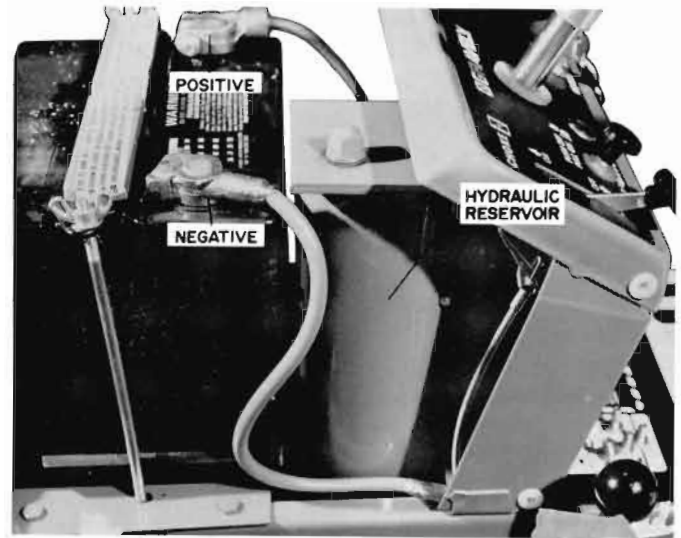

Figure 14

4. Wipe clean and insert dipstick in reservoir. It is not necessary to screw in plug.
5. Remove and read.
6. Add enough fluid (if necessary) to bring level up to full mark. DO NOT OVER FILL.

CAUTION: Do not operate tractor with hood off. (See steering adjustment)

### CHASSIS LUBRICATION

There are 7 lubrication points on the tractor. Lubricate every 8 hours of operation with general purpose grease. See fig 15.

- King Pins — 2
- Front Axle Pivot Pin — 1
- Direction Control Lever — 1
- Steering Assembly — 3

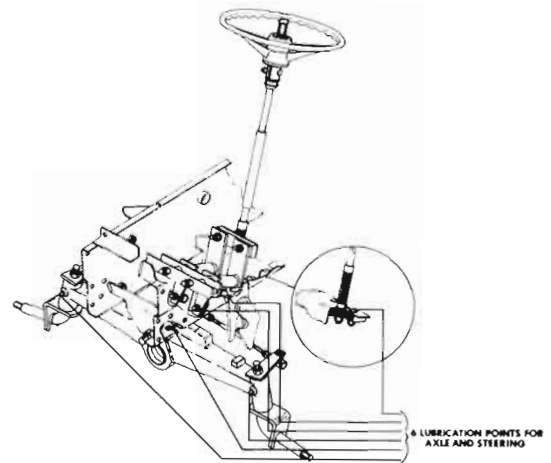

Figure 15

## PROCEDURE

1. Raise front of chassis. Support frame with jack-stands, allowing front axle to hang free, relieving pressure on the bottom bearing points. This allows better grease penetration.
2. Clean grease fittings of all debris.
3. Add grease until it comes out around bearings.
4. Lower chassis and remove excess grease.

Periodic light oiling of pivot points aids operation.

While performing chassis lubrication, apply a small amount of general purpose grease to the rack and pinion mechanism.

## FRONT WHEEL BEARINGS

Repack bearings every 200 hours of operation with wheel bearing grease. Repack after operation in water above the bearings.

Thoroughly clean the old grease from the bearings and wheel parts before repacking. Do not use a fibrous grease.

When reinstalling the wheel; spin the wheel and tighten the wheel nut to the point where the wheel does not "drag" and there is no "play."

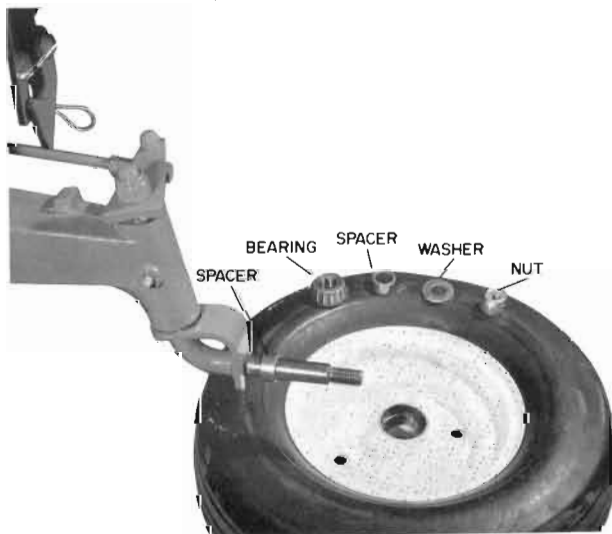

Figure 16

## AIR FILTER

810-812-816T-818T: One Stage filtration

816S: Two stage filtration

810-812-816T-818T

Service every 24 hours of operation or more often under dusty conditions. A precleaner is available, and recommended, for severe dusty conditions.

## PROCEDURE

1. Remove wing nut and cover.
2. Remove filter cartridge.
3. Clean by tapping gently on flat surface.
4. Replace when dirt cannot be tapped off and/or light cannot pass through element.
5. Replace when bent, crushed or damaged.
6. Reinstall and make wing nut finger tight.

## 816S

Clean and re-oil foam precleaner at 3 month intervals or every 24 hours of operation, whichever occurs first. Service more often under dusty conditions.

## PROCEDURE

1. Remove upper wing nut and cover.
2. Remove foam precleaner element by sliding it up off of paper cartridge.
  - A. Wash foam precleaner in liquid detergent and water.
  - B. Squeeze dry.
  - C. Oil with one ounce engine oil. Squeeze to distribute oil evenly.
3. Install foam element over paper cartridge. Reassemble cover and wing nut.

Screw wing nut down finger tight. Yearly or every 100 hours, whichever occurs first, replace paper cartridge. Clean by tapping gently on flat surface. If very dirty, replace cartridge.

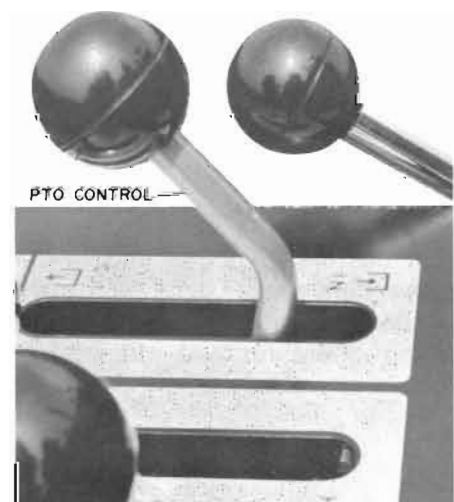

Figure 17

## PTO ADJUSTMENT

Adjust control when free travel is less than  $\frac{1}{2}$ " (12.7 mm) when lever is in the "IN" position. See figure 17.

FREE TRAVEL:  $\frac{1}{2}$ " to 1"  
(12.7 to 25.4 mm)

### PROCEDURE

1. Stop engine and set parking brake.
2. Disconnect PTO rod from transmission when PTO is in "IN."
3. Turn rod to adjust.
  - A. Clockwise increases free travel.
  - B. Counter-clockwise will decrease free travel.
3. Reconnect and measure free travel.
4. Secure with hair pin cotter.

## CLUTCH ADJUSTMENT

Adjust to .060" (1.52 mm) when gap exceeds .080" (2.03 mm).

GAP: .060" to .080" (1.52 — 2.03 mm)

MINIMUM LINING THICKNESS: .020"  
(.508 mm)

### PROCEDURE

1. Tighten clutch stud nuts with gauge between stationary and moveable hubs.
2. Gap must be equal around. Uneven wear will result in clutch failure. See fig 18 and 19.
3. Replace lining hub when lining is less than .020" (.508 mm) or appears to be very thin.

STOP ENGINE AND SET PARKING BRAKE BEFORE PERFORMING MAINTENANCE.

Every 24 hours of operation, lubricate the clutch cam bearing, exposed end of splined clutch shaft, cam rollers and all pivot points of clutch linkage with regular grade oil. This will assist in smoother forward clutch operation and minimize grabbing. Maintain correct clutch adjustment as described. (.060"—.080")

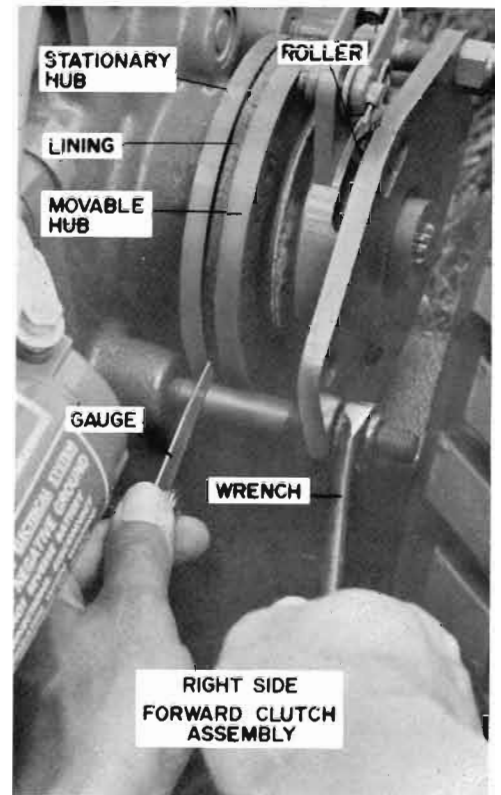

Figure 18

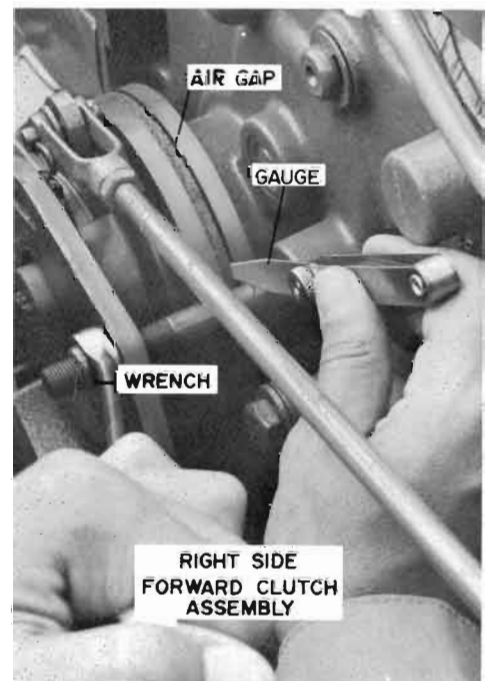

Figure 19



## STEERING ASSEMBLY ADJUSTMENTS

In the event the steering becomes loose, adjustments can be made in the rack and pinion. See fig 20.

Tractor hood must be in place and secure when making steering adjustments.

### PROCEDURE

1. Turn wheels all the way to the right.
2. Tighten the adjusting nuts on the left.
3. Turn wheels all the way to the left.
4. Tighten the adjusting nuts on the right.

DO NOT over tighten the adjusting bolts. Bolts need only be tight enough NOT to allow up or down movement, but have side to side movement.

**WARNING: TRACTOR MUST NOT BE USED WITHOUT THE HOOD IN PLACE; PREMATURE FAILURE OF STEERING WILL RESULT.**

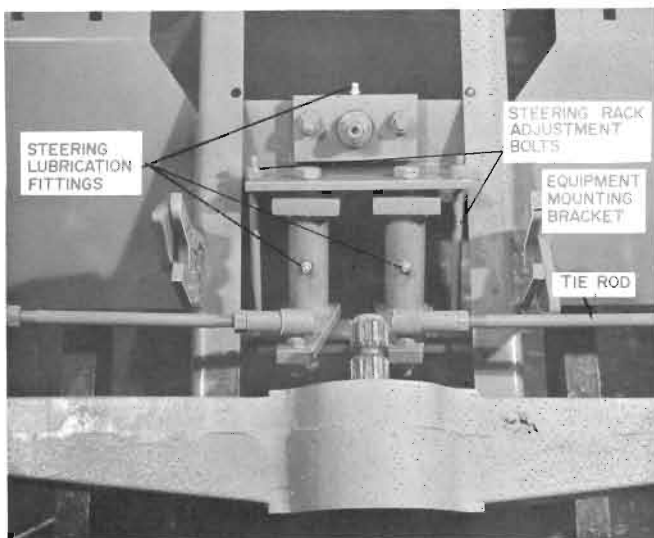

Figure 20

## BRAKE, SERVICE AND PARKING

Maintain proper adjustment for safe operation. Adjust as necessary. Replace brake band when thinnest part of lining is less than .020" (.50 mm) or appears to be very thin.

Replace brake lining band by removing the clevis and mounting bolt. Brake lining band can then be removed. When new band has been installed, readjust brake as explained in ADJUSTMENT PROCEDURE.

## CORRECT ADJUSTMENT

When direction control is fully engaged in either forward or reverse and brake pedal is moved forward, braking should not start until direction control automatically returns to neutral. Timing is accomplished by brake linkage and is essential for safe operation.

### ADJUSTMENT PROCEDURE

1. Park tractor on level ground, and block wheels.
2. With engine stopped put direction control in forward position.
3. Slowly depress brake pedal until control lever returns to neutral. Engage stop rod as explained in CONTROLS section.
4. Observe free travel of brake linkage rod in slot. (Braking action should start at this point.)
5. Remove clevis pin, loosen jam nut and turn clevis until the free movement is taken up in slot. Reconnect clevis and tighten jam nut. See fig 21.
6. Repeat steps 2, 3 or 4 to assure that braking action does not start until direction control is returned to neutral.

**NOTE:** Optional individual rear wheel steering assist brakes are available for 800 Series tractors. Contact your Gravelly dealer for more information.

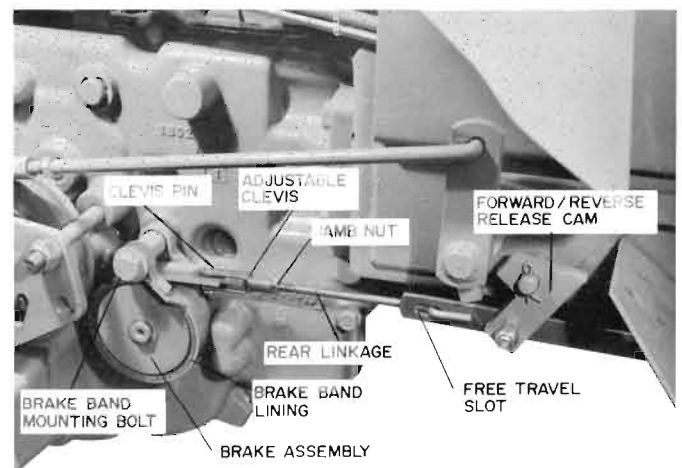

Figure 21

## COOLING SYSTEM

Grass or chaff may clog cooling system after prolonged service when cutting dry grasses or hay. Continued operation with a clogged cooling system causes severe overheating and possible engine damage. Remove blower housing and clean regularly.

**CAUTION:** DO NOT run engine without blower housing and head baffle in place

KEEP THE TRACTOR AND ENGINE CLEAN.

## BATTERY

Check fluid level every 8 hours of operation. Maintain fluid level.

Protect against fire and explosion; do not allow sparks or flames near battery.

The battery may be serviced through the access panel on top of the hood. Press down on the front of the panel, at the hinged side, lift back of panel up and toward front of tractor. See fig 22.

1. Add only distilled water to bring level up to level indicator inside battery (split ring or triangle).
2. Do not over fill or allow electrolyte level to fall below and expose battery plates.
3. Do not use metal funnel to fill battery.
4. Replace caps securely.

## TERMINALS

1. Maintain good electrical contact between cable ends and battery post.
2. Keep terminals tight on battery post and free of corrosion.
3. Clean the battery with a solution of baking soda and water. DO NOT allow the soda to enter the cells of the battery.

## CHARGING & SERVICING

1. Always remove both cables (negative "-" cable first) when charging battery or servicing electrical system.
2. Always wear eye protection when servicing battery.

## JUMP STARTING BATTERY

Caution must be used when jump starting a discharged battery. Improper use of jumper cables can be a definite explosion hazard. Proper procedure can minimize this danger.

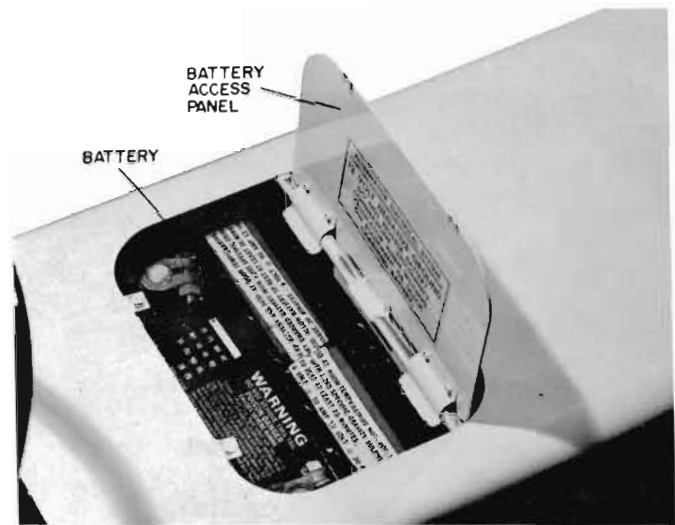

Figure 22

## PROCEDURE

1. Attach the cable to the positive post of both batteries.
2. Attach one end of the remaining cable to the negative post of the booster battery.
3. Attach the remaining end of the cable to the frame, away from the battery, of the vehicle with the discharged battery.

DO NOT attach the negative cable to the negative post of the discharged battery. KEEP sparks away from battery.

TO REMOVE: Reverse the order, removing the ground cable first.

## TIRES

Adjust pressure according to equipment weight. Increase front air pressure when using heavy front mounted equipment such as snowblower.

STANDARD PRESSURE: 12 - 18 psi front and rear.

## REAR WIDTH

### 810-812-816S

Inboard (air valves toward engine)

36¼" (.91 m)

Outboard (air valves away from engine)

41¾" (1.06 m)

### 816T-818T

Outboard position only, due to lack of tire/engine clearance in inboard position.

## FUSE

1. Maintain good electrical contact.
2. Maintain tight spring tension in fuse holder.
3. Replace open (burned-out) fuse. 30 amp
4. Fuse holder is located in lower panel of instrument panel.

## LIGHTS

1. Replace burned-out headlights.
2. Maintain good electrical connection at base of light socket.
3. Remove the four screws holding light panel lens for access to bulbs.

## FASTENERS

### NUTS — BOLTS — SCREWS

When performing other routine maintenance, check with tools to assure tightness and safety of operation.

### HAIR PIN COTTERS

These are "no-tool" fastening devices. When performing other routing maintenance, visually inspect to see that they are in place.

## SPARK PLUG

Remove, inspect, clean and re-gap every 100 hours of operation or more often under heavy load conditions.

## PROCEDURE

1. Use spark plug wrench and remove plug.
2. Clean ceramic area and electrodes of built-up deposits.
3. Re-gap to specifications.
  - A. 810-812-816T-818T: .025" (.635 mm)
  - B. 816S: .030" (.762 mm)
4. Replace spark plug and tighten 25 ft. lbs. (33.9 Nm) torque.
5. Replace wire (connection must snap tight.)

## FUEL TANK

Capacity: 5.3 U.S. Gallons (20.14 liters)

Type Fuel: Fresh, regular grade, 86 octane or higher.

Regular grade lead-free may be used.

DO NOT use ethyl, white or high-test.

Remove fuel strainer from bottom of fuel tank and clean once a year, or when restricted fuel flow is suspected.

## STORAGE

For prolonged out-of-season storage, the following is recommended.

1. Perform all normally scheduled maintenance, including lubrication.
2. Run engine until operating temperature is reached. Drain engine oil, and add fresh oil as recommended in ENGINE LUBRICATION.
3. Drain fuel from system. Run engine until it stops. Remove fuel strainer from bottom of fuel tank and clean.
4. Remove spark plug(s). Pour 2 tablespoons engine oil through spark plug hole(s). Replace plug(s); leave wire off. Crank engine to spread oil. (Approximately 5 seconds.) Turn switch to "OFF" and remove key.
5. Service and charge battery every 2 weeks.

## AFTER STORAGE

1. Re-connect spark plug wire.
2. Perform all normally scheduled maintenance.
3. Charge battery.
4. Fill fuel tank.
5. Start routine service intervals.

## TROUBLE SHOOTING ENGINE

### Will not crank

1. Controls not in "START" position.
2. Discharged battery.
3. Burned-out or corroded fuse.
4. Interlocks not functioning properly.

**Will not start**

1. No gasoline or contaminated fuel.
2. Spark plug needs service.
3. Poor electrical connections or ignition.

**Operates erratically**

1. Spark plug needs service.
2. Contaminated fuel.
3. Clogged air filter.
4. Poor electrical connections or ignition.
5. Clogged cooling system.

**TROUBLE SHOOTING TRANSMISSION**

Clutch "chatters" when direction control is being engaged — and/or clutch slips when direction control is fully engaged.

1. Gap needs adjusting.
2. Contaminated or glazed clutch lining.
3. Clutch lining worn out.
4. No lubrication on clutch parts or linkage.

**Poor braking and/or pedal bottoms.**

1. Linkage needs adjusting.
2. Contaminated brake lining.
3. Brake lining worn out.

**ENGINE**

Models	810	812	816S	816T	818T
Horsepower (at 3600 RPM)	10	12	16	16	18
Spark Plug					
Gap	.025" (.635 mm)	.025" (.635 mm)	.030" (.762 mm)	.025" (.635 mm)	.025" (.635 mm)
type (Champion or equivalent)	RH-10	RH-10	RCU-8	RH-8	RH-8

**OIL RECOMMENDATIONS**

Capacity	
810-812-816S	2 U.S. Quarts (1.88 liters)
816T-818T	2¼ U.S. Quarts (2.138 liters) with filter change.
Grade	API Service SC
Viscosity	Above 0°F (-18°C) SAE 10W-30 Below 0°F (-18°C) SAE 5W-20

**TRANSMISSION**

(all models)	
Oil Capacity	6 U.S. Quarts (5.70 liters)
Grade	SE (API classification)
Viscosity	SAE 10W-30
Clutch gap	.040" - .060" (1.02 - 1.52 mm)
PTO control free travel	1/2" - 1" (12.7 to 25.4 mm)

**GENERAL**

(all models)	
Fuel	
tank capacity	5.3 U.S. Gallons (20.14 liters)
type	Fresh, regular grade leaded or lead-free
Tire pressure	12 - 18 psi front and rear
Ground speed	0.5 to 8.5 mph (.80 to 13.60 km)
Fuse	30 amp
Battery	BCI group 22F, 12 volt negative ground, 43 amp hr.
Hydraulic fluid	Type A Suffix A automatic transmission fluid

The following are approximate ground speeds (mph) with the engine at full throttle.

**FORWARD**

low range	
Gear 1	0.5 (.80 km)
2	0.75 (1.20 km)
3	1.1 (1.76 km)
4	1.7 (2.72 km)

high range	
Gear 1	2.5 (4.0 km)
2	3.8 (6.08 km)
3	5.7 (9.12 km)
4	8.5 (13.60 km)

**REVERSE**

low or high range	
Gear 1	1.1 (1.76 km)
2	1.7 (2.72 km)
3	2.5 (4.0 km)
4	3.8 (6.08 km)